

ITEM NO.	PART NUMBER	DESCRIPTION	DFUCLL24LF61W6400L DMV/QTY.
1	DFUCLL_BODY ASSY		1
3	DFDIW_4FT_LENS		1
4	DFUCLL_MNT STRIP_48IN		2
10	EXISTING FIXTURE		1

WBNQMFVMVNJOBJSF

3FUSP,UJ

STEP ONE: DISCONNECT THE POWER, TAKE OUT ALL COMPONENTS IN THE EXISTING FIXTURE. LEAVING ONLY THE PAN, END CAPS, AND ALL SAEFTY AND CODE REQUIRED ATTACHMENTS ON THE FIXTURE. ESCENTUALLY THE SHELL OF THE OLD FIXTURE.

STEP TWO: REMOVE THE "OLD SHELL" FOR A MOMENT.INSERT THE MNT STRIP(4) INTO THE GRID. MAKE SURE THE BACK EDGE WITH THE .500IN BEND IS FACING THE GRID WITH THE FLAT PLANE OF THE MNT STRIP RESTING ATOP THE LIP OF THE GRID AT EACH END. THEN PUSH THE MNT STRIP UNTIL THE .500IN FLANGE CONTACTS THE GRID ON THE SIDE. PLACE ONE MNT STRIP ON EACH SIDE OF THE GRID LENGTH.

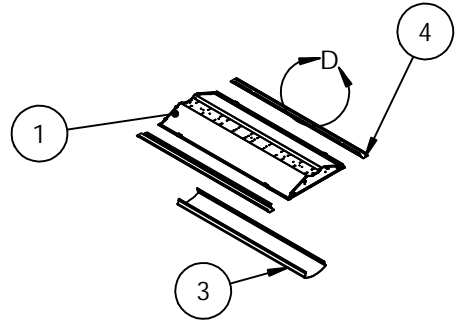

DETAIL D
 SCALE 1 : 2

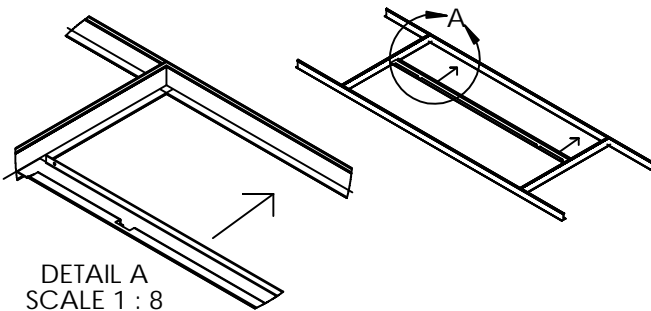

DETAIL A
 SCALE 1 : 8

ON CERTAIN INSTALLMENTS IT WILL REQUIRE A SPECIFIC RAIL FOR EACH SIDE OF THE FIXTURE. IN THIS CASE THE RAIL WITH THE RECTANGLE CUTOUT IN ITS CENTER GOES ON THE SIDE OF THE FIXTURE WITH THE HOOKS (EXAMPLE SHOWN IN DETAIL D), AND THE RAIL WITH NO CUT OUT IN ITS CENTER GOES ON THE LATCH SIDE OF THE FIXTURE

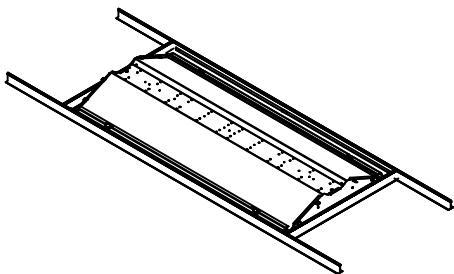

STEP THREE: ONCE THE TWO MNT STRIPS ARE IN PLACE AT EACH SIDE OF THE GRID. REPLACE THE " OLD SHELL" OF PREVIOUS FIXTURE DOWN INTO THE GRID. THE FACE OF THE OLD FIXTURE THAT WAS SITTING ON THE LIP OF THE GRID SHOULD NOW BE SITTING ON TOP OF THE INSIDE FACE OF THE RAILS, ON BOTH SIDES. BE SURE TO RECONNECT ALL SAFETY AND CODE REQUIRED ATTACHMENTS, FROM THE PRE-EXISTING FIXTURE. EACH SIDE OF THE FIXTURE SHOULD BE SITTING ON TOP OF THE MNT STRIPS. THIS WILL ACT AS AN ANCHOR FOR THE DFUCLL.

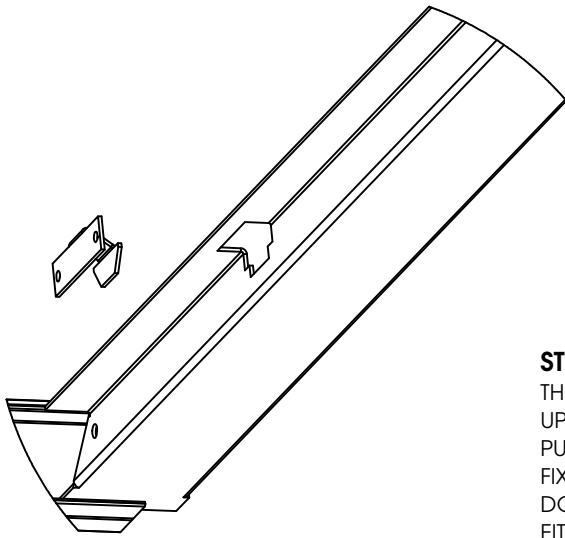

THIS VIEW IS A SIMPLE VIEW TO SHOW THE HOOK AND THE HOLE IN THE MNT STRIP WHERE THE HOOK WILL BE PLACED IN. ALL OTHER PARTS HAVE BEEN SUPPRESSED FOR THIS PURPOSE. THE PAN **WILL BE ATTACHED** TO THIS HOOK WHEN YOU ARE TRYING TO MOUNT THE FIXTURE BODY TO THE MOUNT STRIPS.

STEP FOUR: WITH THE MNT STRIPS IN PLACE POSITION THE BODY SO THAT THE HOOKS ALONG ONE SIDE, LINE UP WITH CORRESPONDING HOLE IN THE MNT STRIP. PUSH THE HOOKS INTO THE HOLES AND NOW THE FIXTURE WILL HANG FROM THESE STRIPS LIKE AN OPEN DOOR. PLEASE NOTE THE HOOKS CAN GO INTO EITHER MNT STRIP SO BE SURE YOU ARE PLACING THE BODY ON THE SIDE YOU WANT. AS THIS MERELY CONTROLS FROM WHICH SIDE THE "DOOR" SWINGS OPEN.

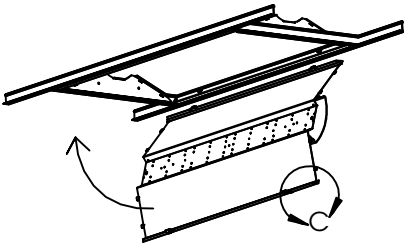

STEP FIVE: WITH THE BODY NOW IN POSITION ALL WIRING SHOULD BE EASILY ACCOMPLISHED. NOW JUST SWING THE "DOOR" CLOSED AND SECURE BY CLOSING THE LATCHES ON THE BODY.

AT THIS POINT ATTACH THE LENS AND YOU ARE DONE.

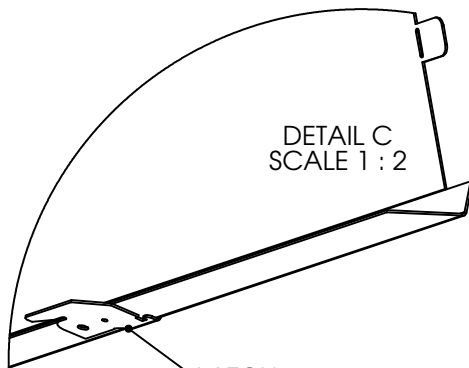

LATCH (CURRENTLY IN CLOSED POSITION)

DFUCLL-BWE REV0



TEXAS FLUORESCENTS, INC. | WWW.TEXASFLUORESCENTS.COM | CARROLLTON | TEXAS



PICTURE A

THIS FIXTURE IS DESIGNED WITH A QUICK DISCONNECT FEATURE. (SEE PICTURE A). MEANING THE FIXTURE ITSELF HAS A SMALL YELLOW DISCONNECT ATTACHMENT.

FIRST PUSH THE TAB AT THE CENTER OF THE CONNECT TO PULL THE CONNECT INTO TWO SECTIONS. THE SMALL SIDE SHOULD REMAIN ATTACHED TO THE POWER WIRES THAT ARE ATTACHED TO THE FIXTURE. THIS LEAVES YOU WITH THE LARGER SECTION TO CONNECT YOUR POWER TO. YOUR POWER WIRE SHOULD HAVE A STANDARD HOT AND NEUTRAL WIRE. ON THE LARGE END OF THE DISCONNECT YOU CAN PUSH THE WIRES FROM YOUR POWER CABLE INTO THE DISCONNECT. THE BLACK SIDE BEING THE HOT AND THE WHITE SIDE BEING FOR THE NEUTRAL. WITH YOUR WIRES ATTACHED YOU CAN NOT PUSH THE TWO SIDE BACK TOGETHER AND YOUR DONE. (SEE DEMONSTRATION A)



DEMONSTRATION A

Installation Instruction Caution:

WARNING – RISK OF FIRE OR ELECTRIC SHOCK. INSTALL THIS KIT ONLY IN THE LUMINAIRES THAT HAS THE CONSTRUCTION FEATURES AND DIMENSIONS SHOWN IN THE PHOTOGRAPHS AND/OR DRAWINGS AND WHERE THE INPUT RATING OF THE RETROFIT KIT DOES NOT EXCEED THE INPUT RATING OF THE LUMINAIRE.

AVERTISSEMENT – RISQUE D'INCENDIE OU DE CHOC ÉLECTRIQUE. N'INSTALLER CE NÉCESSAIRE QUE DANS LES LUMINAIRES DONT LES CARACTÉRISTIQUES DE CONSTRUCTION ET LES DIMENSIONS SONT CONFORME À CELLES ILLUSTRÉES DANS LES PHOTOS ET/OU LES DESSINS ET DONT LA PUISSANCE D'ENTRÉE NOMINALE DU NÉCESSAIRE DE MODERNISATION NE DÉPASSE PAS CELLE DU LUMINAIRE.

THIS RETROFIT KIT IS ACCEPTED AS A COMPONENT OF A LUMINAIRE WHERE THE SUITABILITY OF THE COMBINATION SHALL BE DETERMINED BY AUTHORITIES HAVING JURISDICTION.

LE NÉCESSAIRE DE MODERNISATION EST ACCEPTÉ À TITRE DE COMPOSANT D'UN LUMINAIRE LORSQUE LA PERTINENCE DE LA COMBINAISON DOIT ÊTRE DÉTERMINÉE PAR LES AUTORITÉS COMPÉTENTES

DO NOT MAKE OR ALTER ANY OPEN HOLES IN AN ENCLOSURE OF WIRING OR ELECTRICAL COMPONENTS DURING KIT INSTALLATION.

IL EST INTERDIT DE FAIRE OU DE MODIFIER UNE OUVERTURE DANS UN BOÎTIER DE CÂBLAGE OU DE COMPOSANTS ÉLECTRIQUES AU COURS DE L'INSTALLATION DU NÉCESSAIRE.

WARNING – RISK OF FIRE OR ELECTRIC SHOCK. INSTALLATION OF THIS RETROFIT ASSEMBLY REQUIRES A PERSON FAMILIAR WITH THE CONSTRUCTION AND OPERATION OF THE LUMINAIRE'S ELECTRICAL SYSTEM AND THE HAZARD INVOLVED. IF NOT QUALIFIED, DO NOT ATTEMPT INSTALLATION. CONTACT A QUALIFIED PERSON.

AVERTISSEMENT – RISQUE D'INCENDIE OU DE CHOC ÉLECTRIQUE. L'INSTALLATION DE CE NÉCESSAIRE DE MODERNISATION EXIGE UNE PERSONNE FAMILIÈRE AVEC LA CONSTRUCTION ET LE FONCTIONNEMENT DU SYSTÈME ÉLECTRIQUE DU LUMINAIRE ET DES RISQUES ASSOCIÉS. TOUTE PERSONNE QUI N'EST PAS QUALIFIÉE NE DOIT FAIRE AUCUNE TENTATIVE D'INSTALLATION ET DOIT CONTACTER UNE PERSONNE QUALIFIÉE.